

END

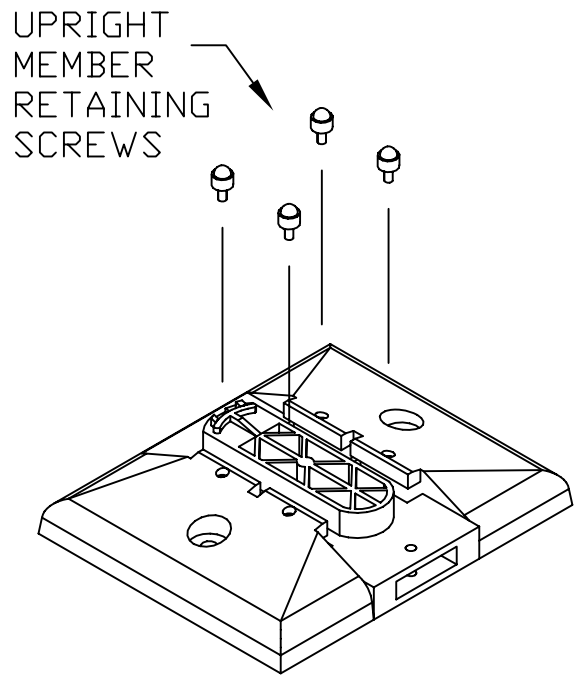

ISOMETRIC

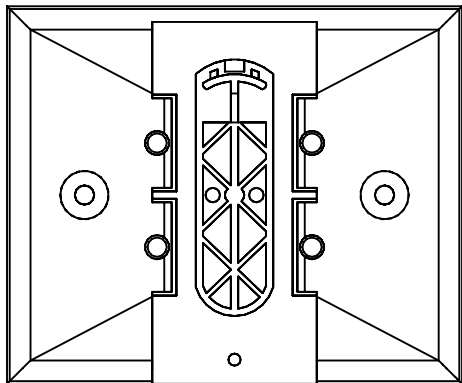

TOP

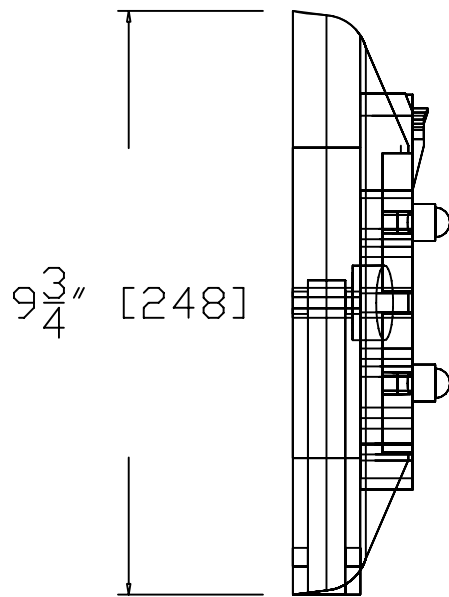

SIDE

All measurements are approximate, as plastic expands and contracts slightly with temperature changes.

QWICK KURB® Model L50 Stand Alone Base Unit

SHEET NO.	DATE:
1 of 2	10/05/09

INTENDED USE

The QWICK KURB® L50 Stand Alone Base Unit is used to secure the L104 MEGA MARKER™, the L125 BIG BOLLARD™, the L125sh™, and other QWICK KURB®, INC. delineation devices to the road surface.

CONTACT INFORMATION

QWICK KURB®, INC.
1916 US 41 South
Ruskin, FL 33570
Phone (813) 645-5072
Fax (813) 645-4856
www.qwickkurb.com

QWICK KURB® Model L50 Stand Alone Base Unit

QWICK KURB®, INC.

SHEET NO.	DATE
2 of 2	10/05/2009



END

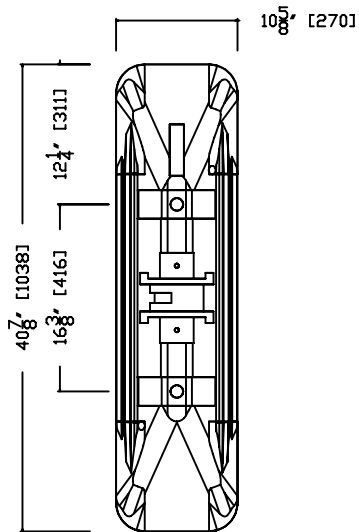

TOP

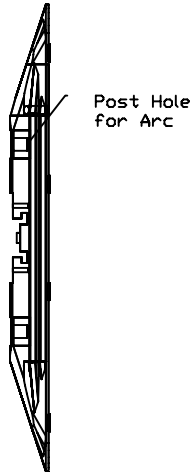

SIDE

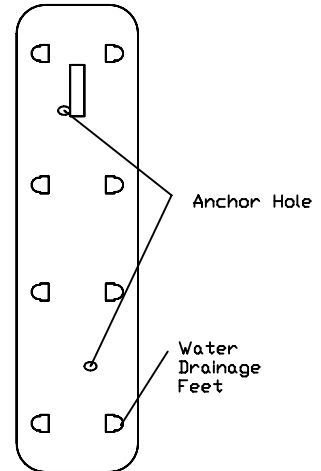

BOTTOM

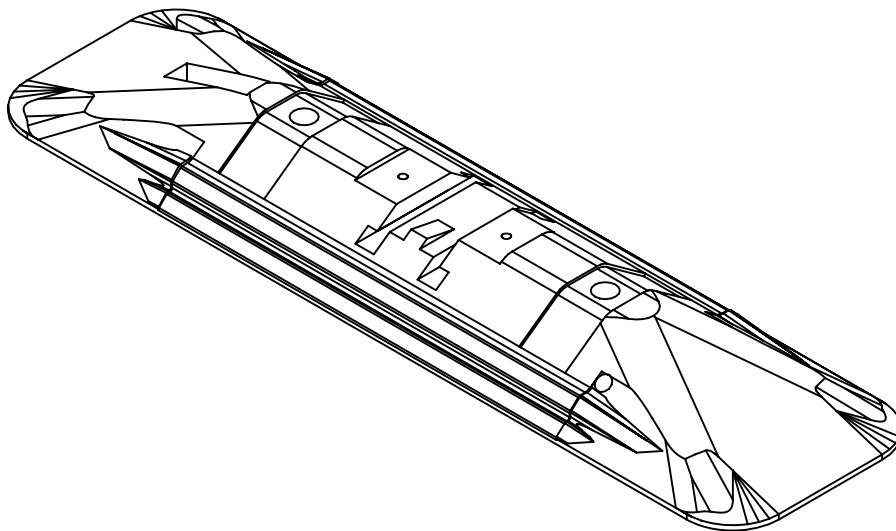

All measurements are approximate, as plastic expands and contracts slightly with temperature changes.

QWICK KURB® L54 Base Unit

SHEET NO.

DATE:

1 of 2

11/30/09

INTENDED USE

The QWICK KURB® Model L54 Base Unit is used to secure the L104 MEGA MARKER™, the L125 BIG BOLLARD™, the L125SH BIG BOLLARD™(Short), and other QWICK KURB®, INC. delineation devices to the road surface.

CONTACT INFORMATION

QWICK KURB®, INC.
1916 US 41 South
Ruskin, FL 33570
Phone (813) 645-5072
Fax (813) 645-4856
www.qwickkurb.com

QWICK KURB® Model L54 BASE UNIT

QWICK KURB®, INC.

SHEET NO.	DATE
2 of 2	11/30/2009

10⁵/₈" [270]

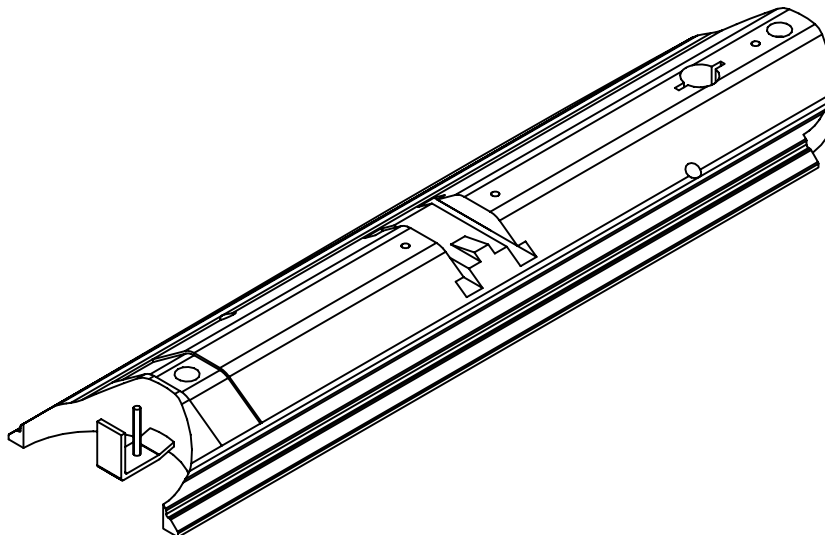
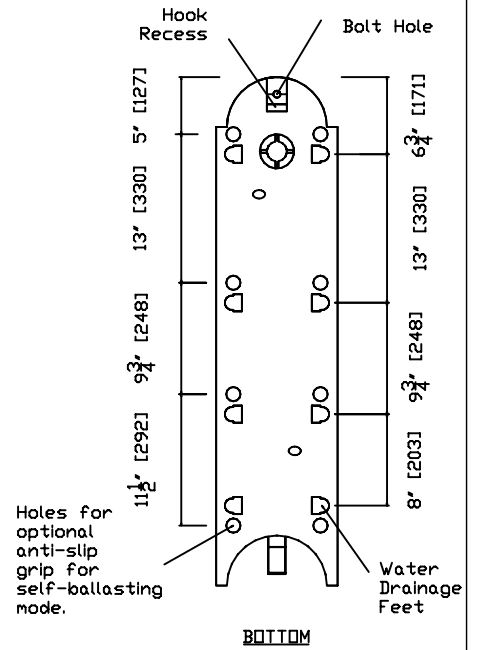
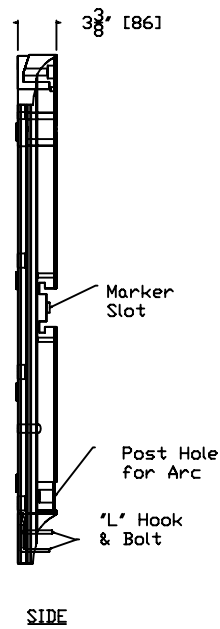
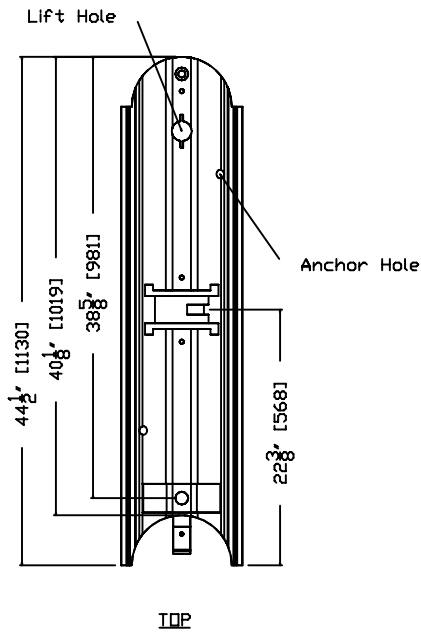
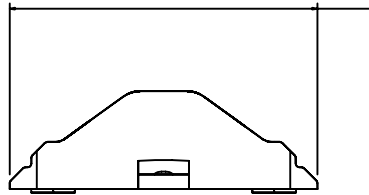

All measurements are approximate, as plastic expands and contracts slightly with temperature changes.

OWICK KURB® L60 Cat. A Lane Separator

SHEET NO.	DATE:
1 of 2	08/20/09

INTENDED USE

The QWICK KURB® Category A Lane Separator is a longitudinal channelizer system of interlocking raised units, profile depicting retro-reflective arcs and reboundable vertical markers/bollards. The system is used instead of asphalt or concrete separators where a more forgiving separator is desired, or in lieu of mere delineators where more robust separation is needed. It provides superior guidance for motorists both day and night. It is ideal as a lane separator, as an edge guide, as a channelizer to ease traffic away from attenuators and restricted areas, and to channel in other desirable ways.

COMPONENTS

The L60 Lane Separator unit is composed of recycled polyethylene, containing three PVC inserts and a stainless steel L-shaped connecting hook. The unit weighs approximately 36lbs [16 kg].

Each unit uses a 3/8" x 2 3/4"[10x70] bolt with washer and lock nut to connect adjoining units.

Optional accessories include reboundable vertical markers/bollards/signs and retro-reflective arcs to improve visibility.

APPROVALS & ACCEPTANCE

FHWA: WZ-109 http://safety.fhwa.dot.gov/roadway_dept/policy_guide/road_hardware/workzone/pdf/wz109.pdf

NCHRP 350

3,500PSI 90% Crush Standard

Category A Standard

CONTACT INFORMATION

QWICK KURB®, INC.

1916 US 41 South

Ruskin, FL 33570

Phone (813) 645-5072

Fax (813) 645-4856

www.qwickkurb.com

QWICK KURB® Model L60 Category A Lane Separator

_____		QWICK KURB® , INC.
SHEET NO.	DATE	
2 of 2	08/20/2009	

9⁵/₈" [244]

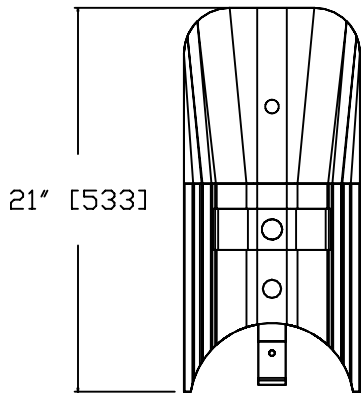
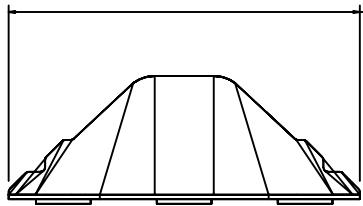

21" [533]

TOP

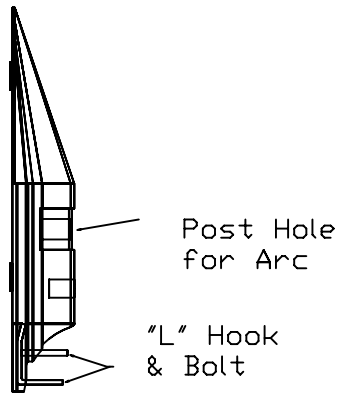

Post Hole for Arc

"L" Hook & Bolt

SIDE

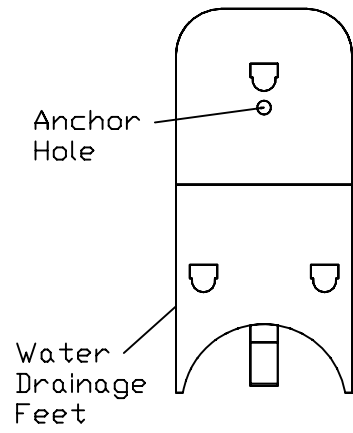

Anchor Hole

Water Drainage Feet

BOTTOM

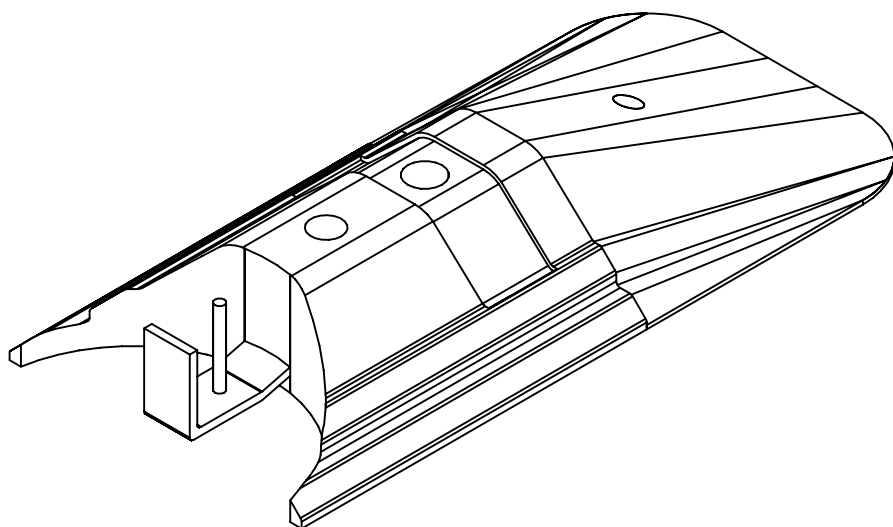

All measurements are approximate, as plastic expands and contracts slightly with temperature changes.

OWICK KURB® L61 Male End Unit

SHEET NO.

DATE:

1 of 2

08/28/09

INTENDED USE

The QWICK KURB® L61 Male End Unit connects to the adjoining L60 Separator at the beginning of each run of separators to create a gentle sloping face to tires of oncoming traffic.

CONTACT INFORMATION

QWICK KURB®, INC.

1916 US 41 South

Ruskin, FL 33570

Phone (813) 645-5072

Fax (813) 645-4856

www.qwickkurb.com

QWICK KURB® Model L61 Male End Unit

QWICK KURB®, INC.

SHEET NO.	DATE
2 of 2	08/28/2009

9⁵/₈" [244]

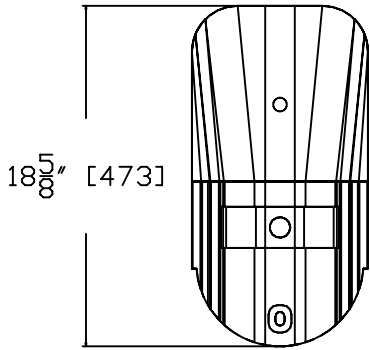
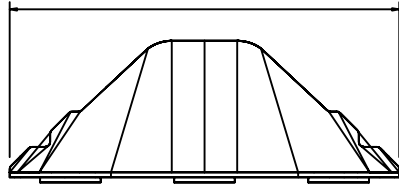

18⁵/₈" [473]

TOP



Post Hole
for Arc

SIDE

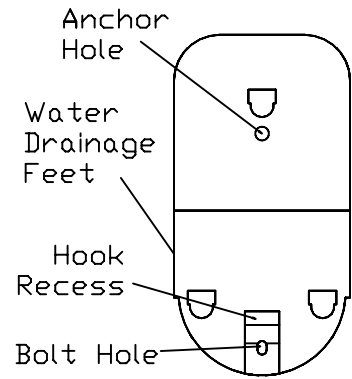

Anchor
Hole

Water
Drainage
Feet

Hook
Recess

Bolt Hole

BOTTOM

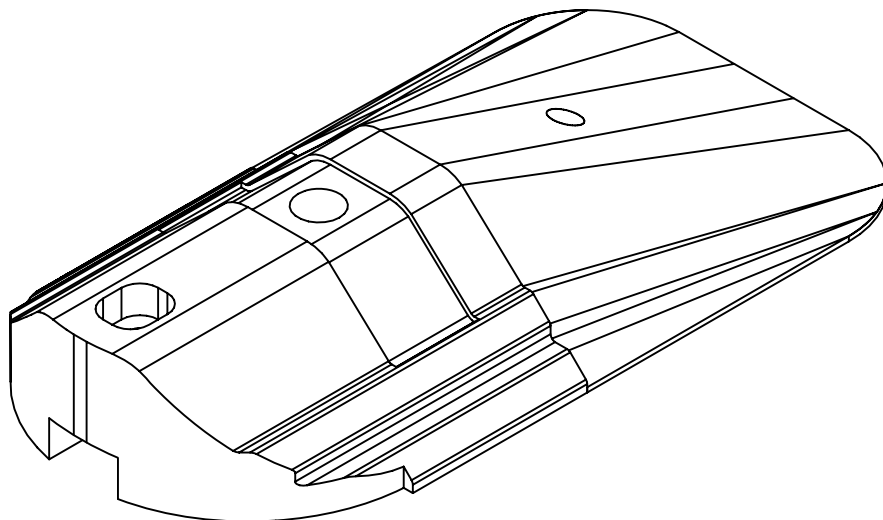

All measurements are approximate, as plastic expands and contracts slightly with temperature changes.

QWICK KURB® L62 Female End Unit

SHEET NO.

DATE:

1 of 2

08/28/09

INTENDED USE

The QWICK KURB® L62 Female End Unit connects to the adjoining L60 Separator at the end of each run of separators to create a gentle sloping face to tires of oncoming traffic.

CONTACT INFORMATION

QWICK KURB®, INC.

1916 US 41 South

Ruskin, FL 33570

Phone (813) 645-5072

Fax (813) 645-4856

www.qwickkurb.com

QWICK KURB® Model L62 Female End Unit

QWICK KURB®, INC.

SHEET NO.	DATE
2 of 2	08/28/2009

7" [179]

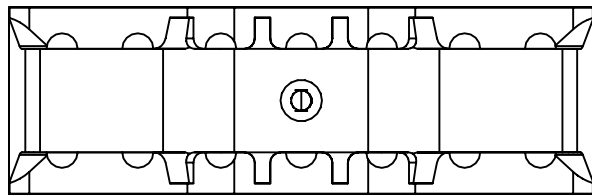

2 1/4" [57]

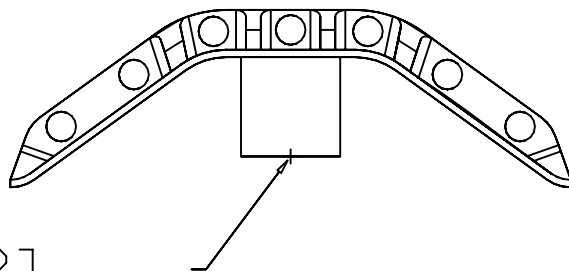

2 3/8" [60]

Ø1 1/4" [Ø32]

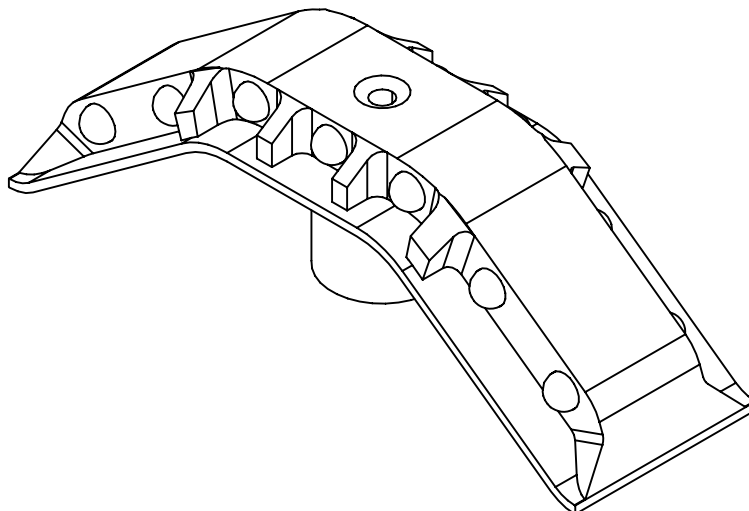

All measurements are approximate, as plastic expands and contracts slightly with temperature changes.

OWICK KURB® Model L65 Reflective Arc

SHEET NO.

DATE:

1 of 2

08/12/09

INTENDED USE

The QWICK KURB® L65 Reflective Arc should be installed on each Separator unit. The L65 is designed in an arc shape to aid motorists, in darkened conditions, to identify the Separator as a raised element. A flat design would mislead motorists into believing the Separator was a flat surface.

CONTACT INFORMATION

QWICK KURB®, INC.

1916 US 41 South

Ruskin, FL 33570

Phone (813) 645-5072

Fax (813) 645-4856

www.qwickkurb.com

QWICK KURB® Model L65 Reflective Arc

QWICK KURB®, INC.

SHEET NO.	DATE
2 of 2	08/12/2009

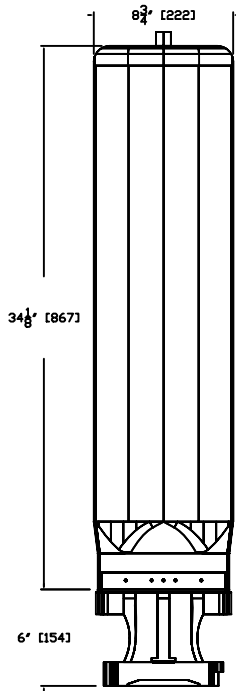

8' x 29' [203 x 737]
Type III
Reflective Sheeting

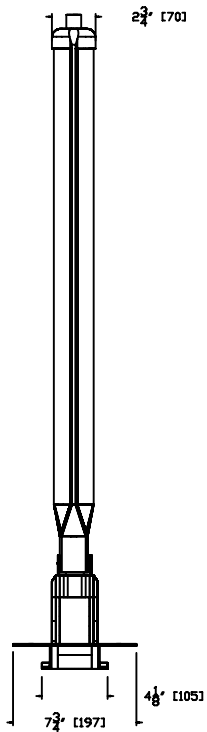
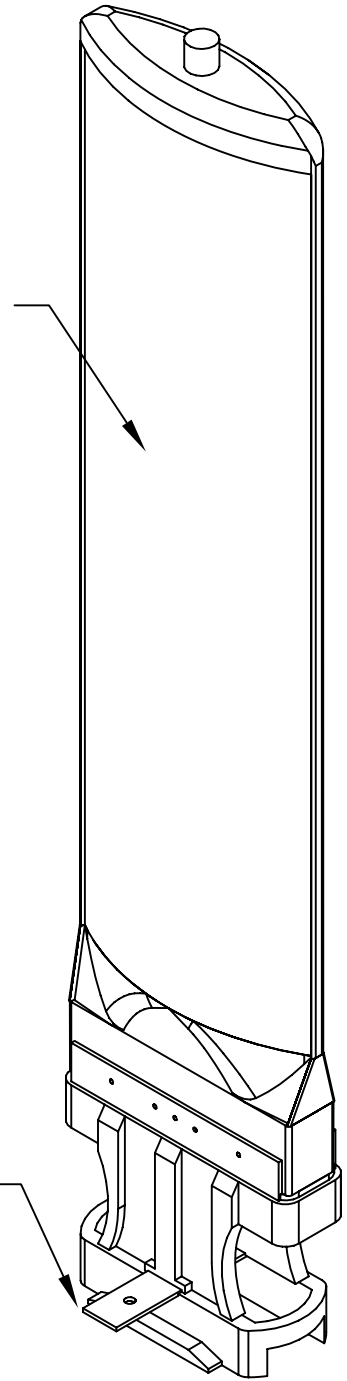

All measurements are approximate, as plastic expands and contracts slightly with temperature changes.

OWICK KURB® Model L104 MEGA MARKER™

SHEET NO.	DATE:
1 of 2	10/05/09

INTENDED USE

The QWICK KURB® Model L104 MEGA MARKER™ is a large marker designed to be clearly visible in order to demarcate vehicular lanes as a longitudinal channelizer. The L104 attaches directly to the L60 Category A Lane Separator, the L50 Stand Alone Base Unit and other QWICK KURB®, INC. mounting devices.

CONTACT INFORMATION

QWICK KURB®, INC.

1916 US 41 South

Ruskin, FL 33570

Phone (813) 645-5072

Fax (813) 645-4856

www.qwickkurb.com

QWICK KURB® Model L104 MEGA MARKER™

QWICK KURB®, INC.

SHEET NO.	DATE
2 of 2	10/05/2009

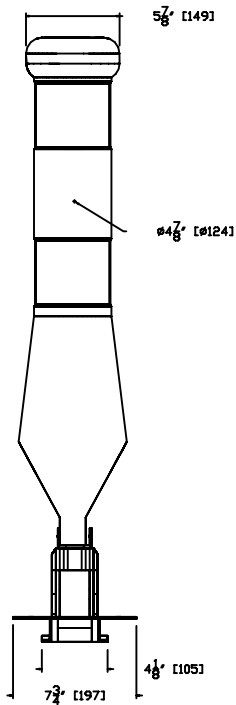
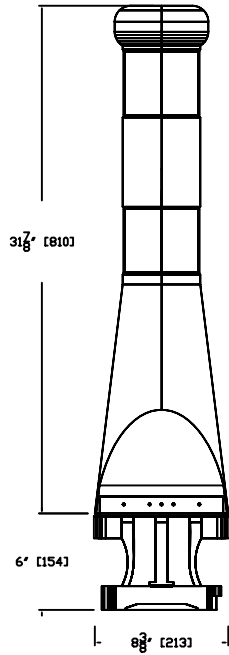

4' x 15' [102 x 381]
Type III
Reflective Sheeting

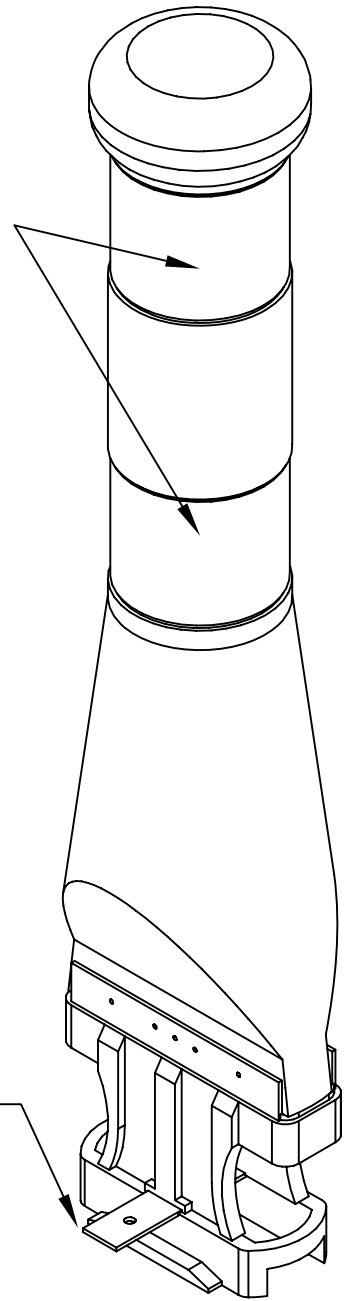

All measurements are approximate, as plastic expands and contracts slightly with temperature changes.

QWICK KURB® Model L125 BIG BOLLARD™

SHEET NO.	DATE:
1 of 2	10/05/09

INTENDED USE

The QWICK KURB® Model L125 BIG BOLLARD™ is a large bollard designed to be clearly visible in order to demarcate vehicular lanes as a longitudinal channelizer. The L125 attaches directly to the L60 Category A Lane Separator, the L50 Stand Alone Base Unit and other QWICK KURB®, INC. mounting devices.

CONTACT INFORMATION

QWICK KURB®, INC.

1916 US 41 South

Ruskin, FL 33570

Phone (813) 645-5072

Fax (813) 645-4856

www.qwickkurb.com

QWICK KURB® Model L125 BIG BOLLARD™

QWICK KURB®, INC.

SHEET NO.	DATE
2 of 2	10/05/2009

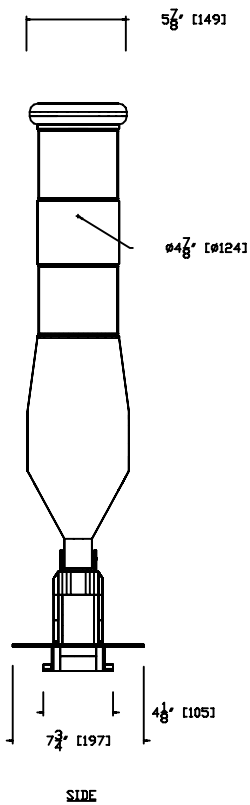
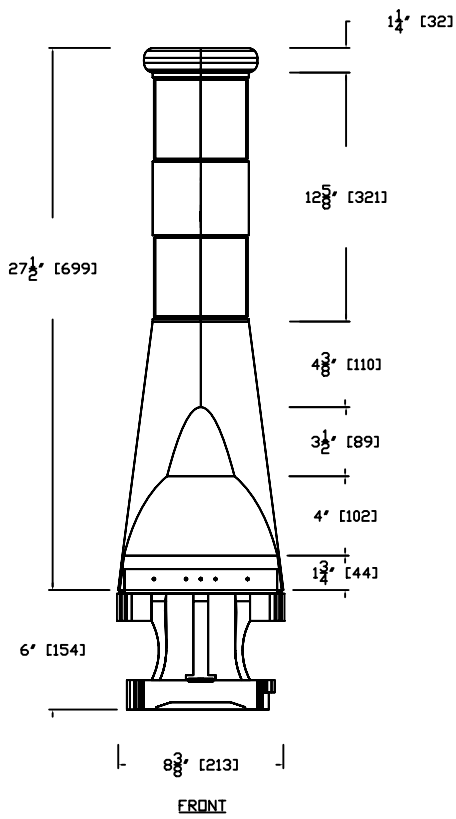

4' x 15' [102 x 381]
 Type III
 Reflective Sheeting

Stabilizing
 Bar

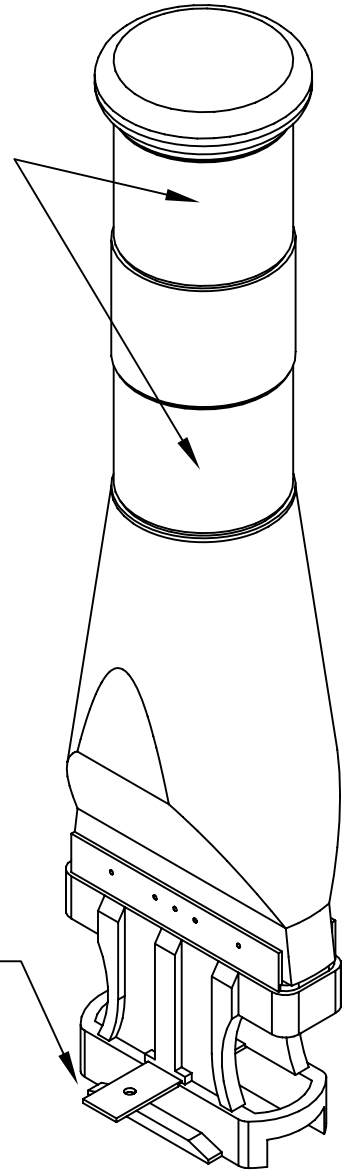

All measurements are approximate, as plastic expands and contracts slightly with temperature changes.

OWICK KURB® Model L125SH BIG BOLLARD™ (Short)

SHEET NO.	DATE:
1 of 2	11/30/09

INTENDED USE

The QWICK KURB® Model L125SH BIG BOLLARD™ (Short) is a large bollard designed to be clearly visible in order to demarcate vehicular lanes as a longitudinal channelizer. The L125SH attaches directly to the L60 Category A Lane Separator, the L50 Stand Alone Base Unit and other QWICK KURB®, INC. mounting devices.

CONTACT INFORMATION

QWICK KURB®, INC.

1916 US 41 South

Ruskin, FL 33570

Phone (813) 645-5072

Fax (813) 645-4856

www.qwickkurb.com

QWICK KURB® Model L125SH BIG BOLLARD™ (Short)

QWICK KURB®, INC.

SHEET NO.	DATE
2 of 2	11/30/2009

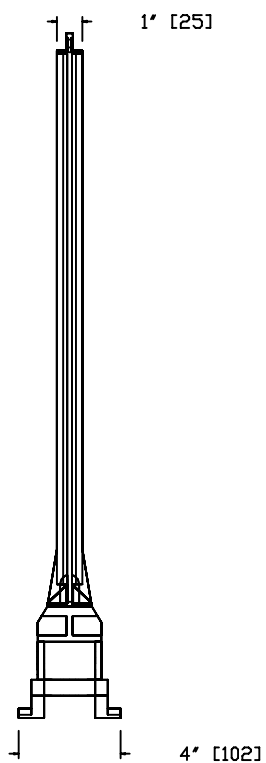
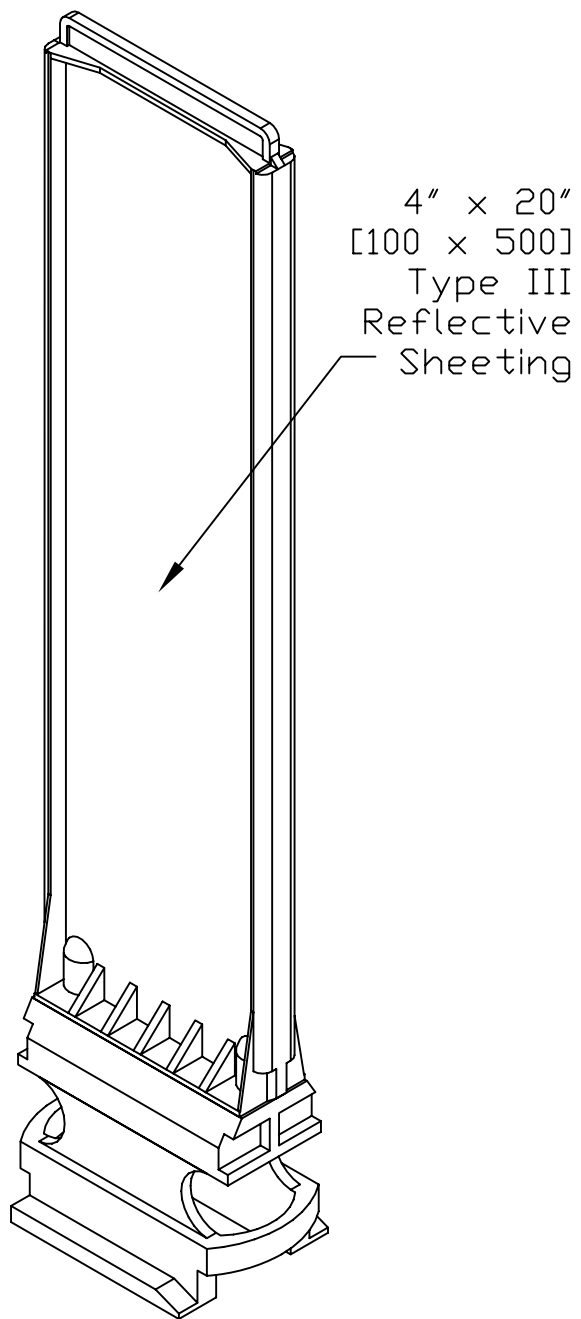
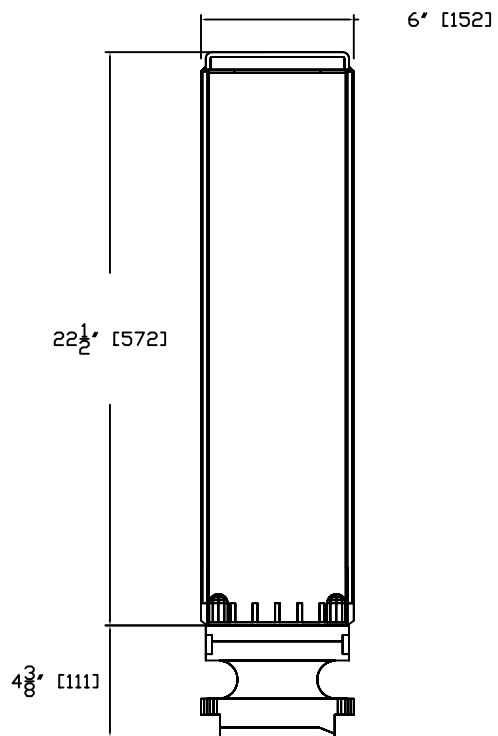

All measurements are approximate, as plastic expands and contracts slightly with temperature changes.

QWICK KURB® Model L84 Short Panel™

SHEET NO.	DATE:
1 of 2	08/31/09

INTENDED USE

The QWICK KURB® L84 Short Panel is used on L60 Separators when deployed unballasted in active work-zones. The panel provides enhanced delineation for motorists.

CONTACT INFORMATION

QWICK KURB®, INC.

1916 US 41 South

Ruskin, FL 33570

Phone (813) 645-5072

Fax (813) 645-4856

www.qwickkurb.com

QWICK KURB® Model L84 Short Panel™

QWICK KURB®, INC.

SHEET NO.	DATE
2 of 2	08/31/2009